

Gravimetric Dosing System GDS

Solutions ...

Combining the well-proven Octagon throughput measurement and screw feeder units, the GDS system offers highest performance in gravimetric dosing and extruder control. Both main material and additives are measured by loss of weight, a process assuring highest accuracy and reliability.

... for extrusions lines ...

The GDS system is fitted directly at the material intake of the extruder thereby eliminating any demixing of different materials. An additional mixer is not required. The sophisticated control concept prevents any overdosing after a change of dosing screw.

... continuous and accurate.

The dosing system is equipped with its own process electronics. Via a fieldbus interface it connects to a central computer where the target and actual data are displayed. Several display modules are available for the user.



Fully-met requirements:

- Highest measuring and dosing accuracy
- High degree of linearity over entire measuring range
- Secure in functioning
- Perfectly adaptable by modular design

Why use gravimetrics?

- Accurate proportions of all component materials
- Evenly distributed colouring
- Reproducible film quality
- No demixing of components as dosing units are fitted directly at material intake of extruder

Optimal integration

- Mechanical and electrical installation fast and simple
- Communication via fieldbus interface (such as a profibus)
- Easily integrated by simply connecting BUS cable, compressed air and power supply
- „Plug and Run“

Octagon dosing modules: For highly advanced technology in extrusion control

Field of application:

Mono- and coextrusion of

- Film
- Sheet
- Tiles
- Pipes
- Profiles

The GDS dosing system may be used as a stand-alone system or serve as a module for fast and simple integration in a SPS or fieldbus system.

It may be extended to up to 6 components per extruder.

Clear display:

- Status display
- Dosing mode
- Function modes
- Dosing release



Dosing controller GDS

Simple handling:

A change of dosing screws is simple and requires little effort. After every change, the system automatically recognises screw size and proceeds with re-configuration of the basic parameter for the component.

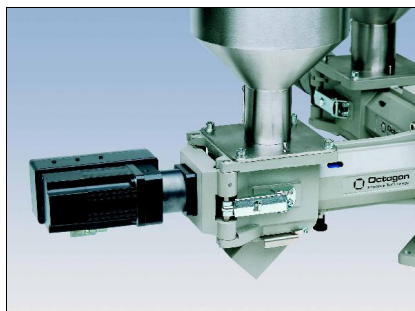

Dosing drive



Dosing drive (open)

Wide selection of dosing screws

Six screw sizes with appropriate sleeve are available for a throughput range of 0.3 to 340 kg/h. For easy recognition, screws and sleeves are marked with a colour code.



Octagon
Process Technology GmbH
Nuernberger Straße 119
D-97076 Wuerzburg

Phone +49 931 27 96 70
Fax +49 931 27 47 19

contact@octagon-gmbh.de
www.octagon-gmbh.de

Accuracy with continuous dosing

Continuous dosing of additives directly at the material intake of the extruder ensuring

- no "loss of blend" of components
- evenly distributed coloring
- highest blending accuracy

